

## 40V 250mA Ultralow-Quiescent-Current LDO

### ■ DESCRIPTION

The HM73XXHB ultra-low quiescent current regulator features low dropout voltage and low current in the standby mode. With less than 1.5 $\mu$ A quiescent current at no load, the HM73XXHB is ideally suited for standby micro-control-unit systems, especially for always-on applications like E-meters, fire alarms, smoke detectors and other battery operated systems. The HM73XXHB retains all of the features that are common to low dropout regulators including a low dropout PMOS pass device, short circuit protection, and thermal shutdown.

The HM73XXHB has a 40-V maximum operating voltage limit, A -40°C to 125°C operating temperature range, and  $\pm$ 2% output voltage tolerance over the entire output current, input voltage, and temperature range. The HM73XXHB is available in a TO-92 through-hole and SOT23-5, SOT-223, SOT89-3 surface mount packages.

### ■ FEATURES

- VIN Range up to 40V
- Output Voltage Tolerances of  $\pm$ 2% Over the Temperature Range
- Output Current of 250 mA
- Ultra Low Quiescent Current ( $I_Q=1.2 \mu A$ )
- Dropout Voltage Typically 1200 mV at  $I_{OUT} = 250 \text{ mA}$
- Internal Thermal Overload Protection
- Internal Short-Circuit Current Limit
- Ceramic Capacitor Stable

### ■ APPLICATIONS

- E-meters, Water Meters and Gas Meters
- Fire Alarm, Smoke Detector
- Appliances and White Goods

### ■ Typical Application Circuit

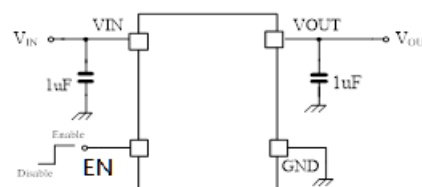
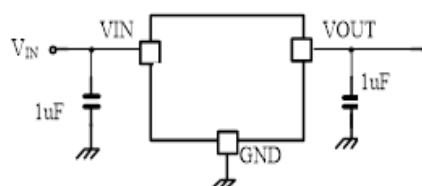

Ceramic Capacitor Stable

■ **BLOCK DIAGRAM**

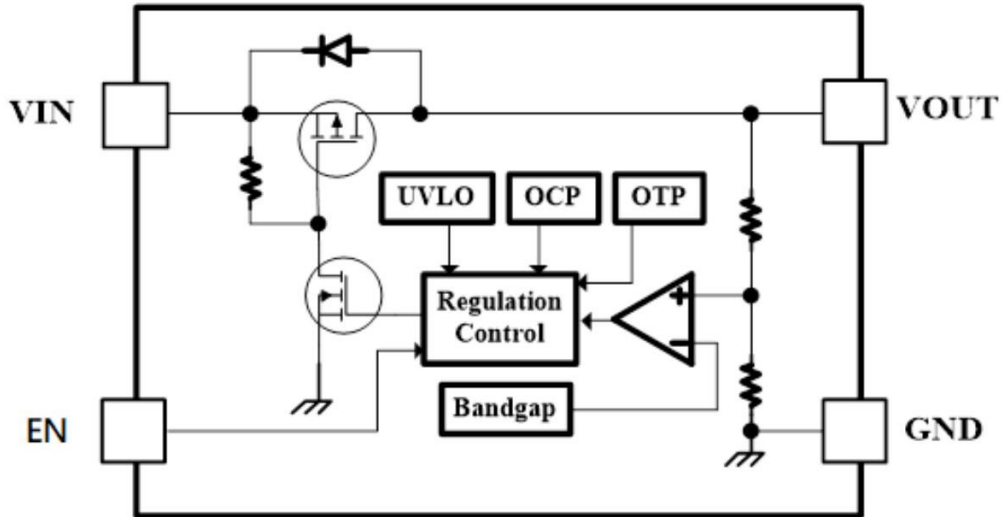

■ **RECOMMEND PACKAGE TYPE**

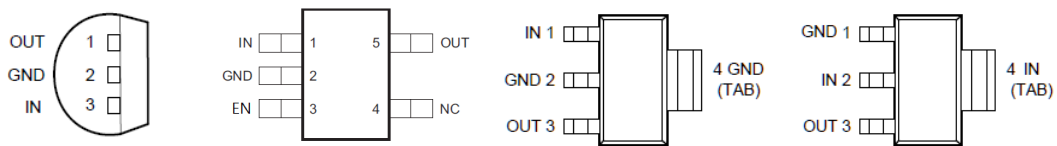

Pin Name	Pin No. TO-92	Pin No. SOT23-5	Pin No. SOT-223 SOT89-3	Pin No. SOT-223 SOT89-3	Pin Function
VOUT	1	5	3	3	Output Voltage Pin
GND	2	2	2,4	1	Ground
VIN	3	1	1	2,4	Input Voltage pin
EN	--	3	--	--	Enable

■ **ABSOLUTE MAXIMUM RATINGS** (T<sub>a</sub>=25°C, Note)

VIN ----- -0.3V to +45V  
 Junction Temperature----- 125°C  
 Lead Temperature (Soldering, 10 sec.)----- 300°C  
 Storage Temperature ----- -65°C to 150°C

**Recommended Operating Conditions**

Input Voltage, VIN ----- +2.7V to +40V  
 Junction Temperature ----- -40°C to 125°C

■ ELECTRICAL CHARACTERISTICS

$V_{IN}=V_{OUT} + 1V$ ,  $I_{OUT}=1mA$ ,  $C_{IN}=C_{OUT}=2.2\mu F$ ,  $T_J=25^{\circ}C$ , unless otherwise specified

Parameter	Symbol	Conditions	Min	Typ	Max	Unit
Output Voltage Range	$V_{OUT}$		1.5		5.5	V
Output Voltage Accuracy	$\Delta V_{OUT}$		-2		2	%
Line Regulation	$\Delta V_{LINE}$	$V_{IN} = V_{OUT} + 1V$ to 40V		2	12	mV
Load Regulation	$\Delta V_{LOAD}$	$I_{OUT} = 1mA$ to 100mA		3	15	mV
		$I_{OUT} = 1mA$ to 250mA		15	30	
Dropout Voltage	$V_{DROP}$	$I_{OUT} = 100mA$		400		mV
		$I_{OUT} = 250mA$		1200		mV
Quiescent Current	$I_Q$	$T_J = 25^{\circ}C$		1.2	2.5	$\mu A$
Current Limit	$I_{CL}$		270	300		mA
Enable high level	$V_{ENHI}$		0.9			V
Enable low level	$V_{ENLO}$				0.4	V
Enable pin pull high current	$I_{EN}$			0.3		$\mu A$
Power-supply rejection ratio	PSRR	$f = 1kHz$		80		dB
		$f = 10kHz$		60		dB

■ **TYPICAL CHARACTERISTICS**

$V_{IN}=V_{OUT} + 1V$ ,  $I_{OUT}=1mA$ ,  $V_{OUT}=3.3V$ ,  $C_{IN}=C_{OUT}=1\mu F$ ,  $T_J=25^\circ C$ , unless otherwise specified

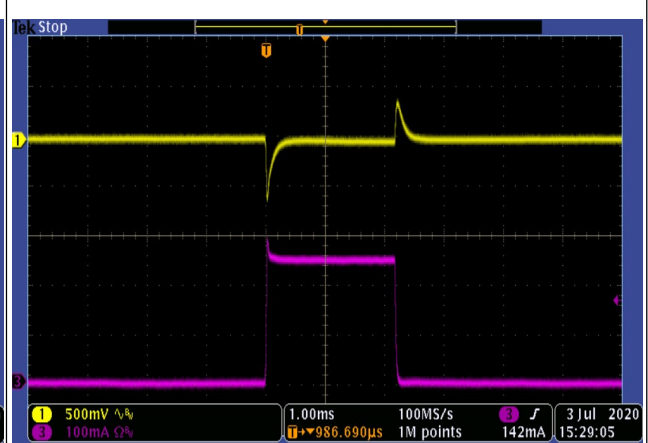
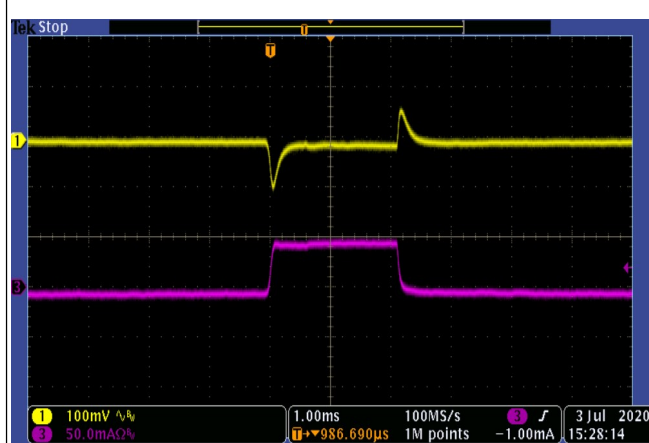
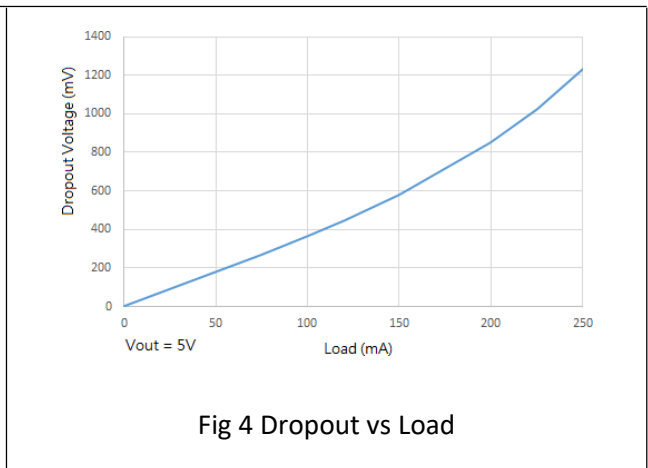
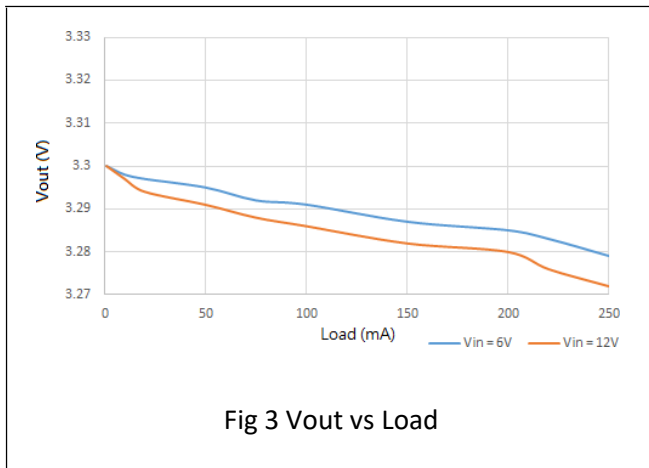
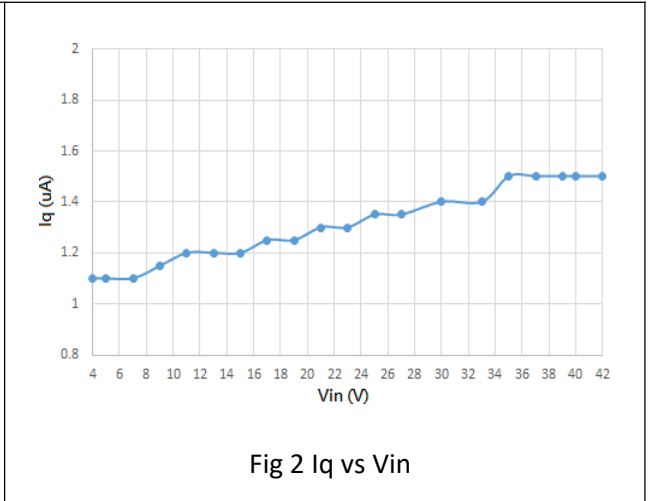
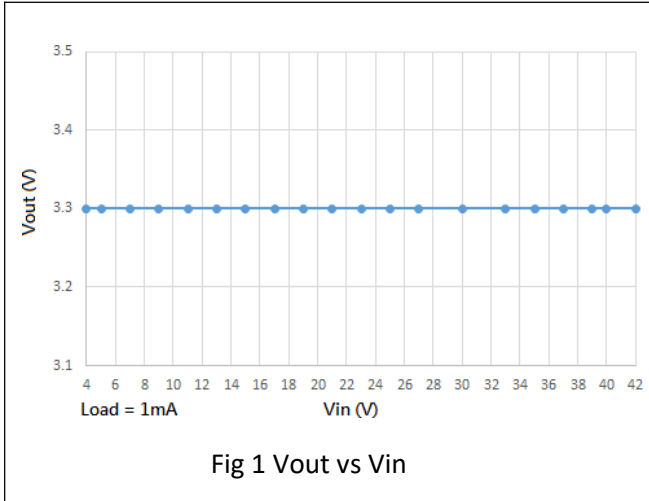

Fig 5 Vout Load Transient (0 to 50mA)

Fig 6 Vout Load Transient (1 to 250mA)

■ **TYPICAL CHARACTERISTICS**

$V_{IN}=V_{OUT} + 1V$ ,  $I_{OUT}=1mA$ ,  $V_{OUT}=3.3V$ ,  $C_{IN}=C_{OUT}=1\mu F$ ,  $T_J=25^{\circ}C$ , unless otherwise specified

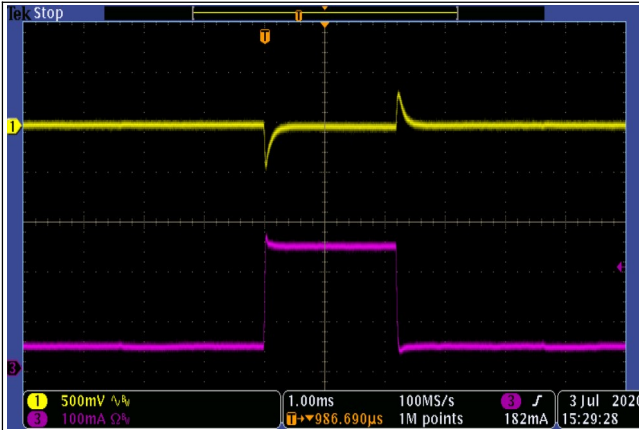

Fig 7 Vout Load Transient (50 to 250mA)

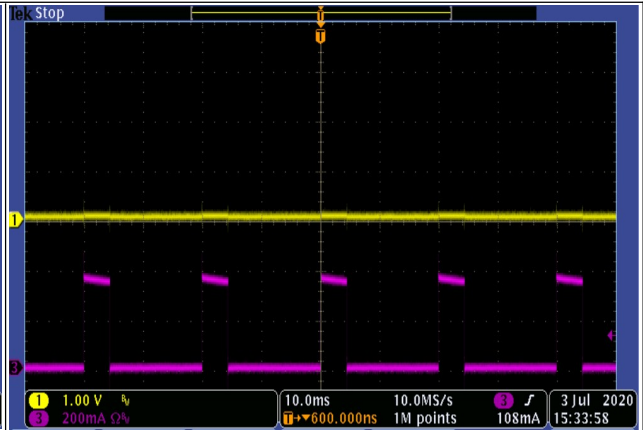

Fig 8 Vout Short to GND

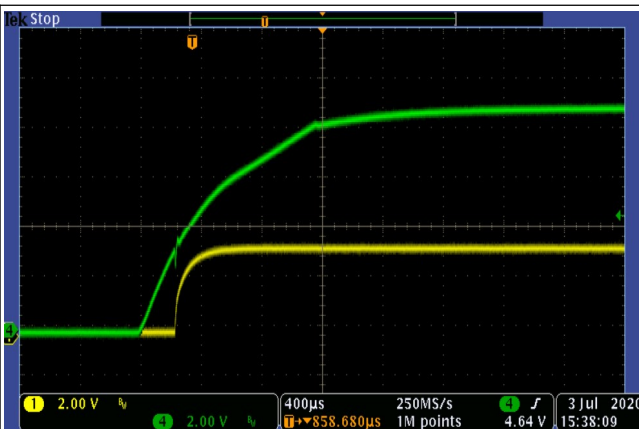

Fig 9 Vin Start up