

1A Low Dropout LDO with Adjustable Output

General Description

The HM6223B series are CMOS-based low-dropout, low-power linear regulators, offering 1A with low dropout voltage, high ripple rejection, high output accuracy and low supply current. The HM6223B consist of an accurate voltage-reference block, an error amplifier, a voltage-setting resistor net, a PMOSFET pass device, a thermal-shutdown circuit, and a current limit circuit with short protection.

The HM6223B series use a type of outstanding CMOS process to minimize the supply current. A low on-resistance PMOS pass device is equipped for lower dropout voltage. HM6223B also possess the CE function to save more energy and extend the battery life.

The HM6223B series can choose the output current 1.0A. The output voltage can be adjusted from 0.75v to 4.3v using two external resistors.

The HM6223B series are available in the DFN6 package (2mm*2mm).

Features

- Wide Input Voltage Range: 1.8V to 5.5V
- Output Current: 1.0A optional
- Adjustable Output Voltage Range: 0.75V to 4.3V
- Very Low Iq: 110μA
- Excellent Load/Line Transient Response
- Line Regulation: 0.02% typical
- Built-in overcurrent protection and thermal shutdown circuit
- Built-in Auto-discharging circuit
- Reverse Current Protection
- Package: DFN6

Applications

- Constant-voltage power supply for battery-powered device
- Constant-voltage power supply for TV, notebook PC and home electric appliance
- Constant-voltage power supply for portable equipment
- Label Information

HM6223B-ADJX



Package specification

D: DFN6-2mm*2mm package

P:SOT89-5L package

Pin Configuration

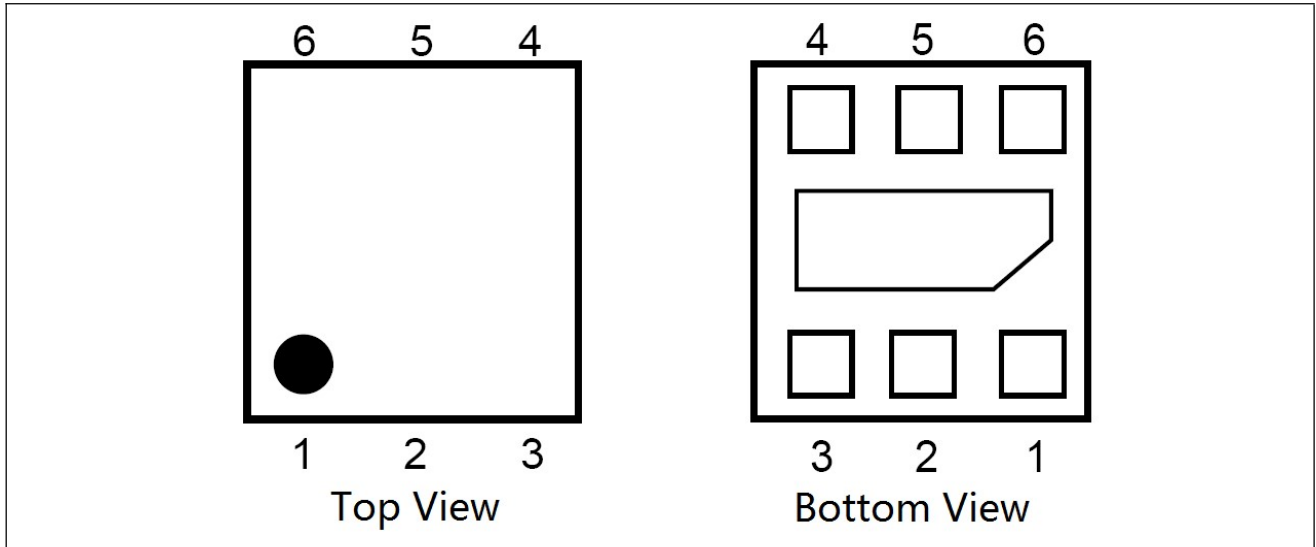

Pin Function

Pin	Symbol	Pin Description
1	VOUT	Output Pin
2	ADJ	Adjustable Regulator Feedback Input. Connect to output voltage resistor divider central node.
3	GND	Ground Pin
4	CE	Chip Enable Pin
5	NC	No connect
6	VDD	Input Pin

Block Diagram

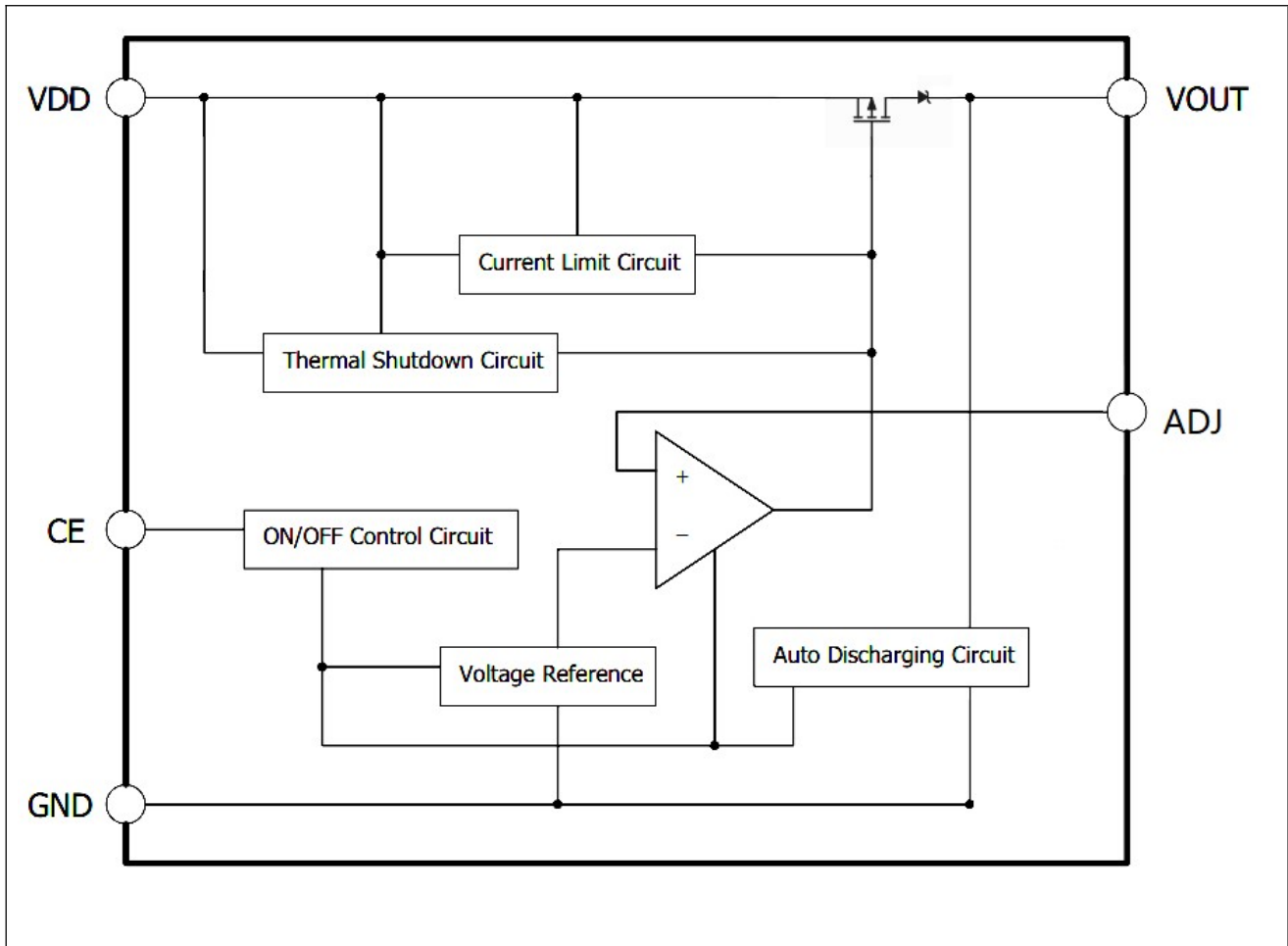

Functional Description

Input Capacitor

A 1 μ F ceramic capacitor is recommended to connect between V_{DO} and GND pins to decouple input power supply glitch and noise. The amount of the capacitance may be increased without limit. This input capacitor must be located as close as possible to the device to assure input stability and less noise. For PCB layout, a wide copper trace is required for both V_{IN} and GND.

Please pay attention, in the case of high impedance of the power supply, the input capacitance of the IC is small or the capacitor is not connected, the oscillation may occur. When the capacitance value of the output capacitor is greater than the capacitance value of the input capacitor, it is possible to generate oscillation.

Output Capacitor

An output capacitor is required for the stability of the LDO. The recommended output capacitance is 1 μ F, ceramic capacitor is recommended, and temperature characteristics are X7R or X5R. Higher capacitance values help to improve load/line transient response. The output capacitance may be increased to keep low undershoot/overshoot. Place output capacitor as close as possible to V_{OUT} and GND pins.

CE Pin Operation

The HM6223B is turned on by setting the CE pin to “H”. Since the CE pin is neither pulled down nor pulled up internally, do not set it in floating status. When the CE pin is not used, connect the CE pin with V_{DD} to keep the LDO in operating mode.

Current Limit Protection

When output current of V_{OUT} pin is higher than current limit threshold or the V_{OUT} pin is direct short to GND, the current limit protection will be triggered and clamp the output current at a predesigned level to prevent over-current and thermal damage. HM6223B output current limit will be 1.4A.

Thermal Shutdown Protection

Thermal protection disables the output when the junction temperature rises to approximately +155°C, allowing the device to cool down. When the junction temperature reduces to approximately +120°C the output circuit is enabled again. Depending on power dissipation, thermal resistance, and ambient temperature, the thermal protection circuit may cycle on and off. This cycling limits the heat dissipation of the regulator, protecting it from damage due to overheating.

Reverse Current Protection Circuit

If V_{OUT} is higher than V_{IN}, the parasitic diode of Pch output transistor becomes forward direction. As a result, the current flows from V_{OUT} pin to V_{DD} pin.

The HM6223B series switches the mode to the reverse current protection mode before V_{IN} becomes lower than V_{OUT} by connecting the parasitic diode of Pch output transistor to the backward direction, and connecting the gate to V_{OUT} pin. As a result, the Pch output transistor is turned off. However, from V_{OUT} pin to GND pin, via the internal divider resistors, very small current I_{REV} flows.

Auto Discharging

When the CE pin set to “L”, the output circuit will be disable immediately, and the Auto-Discharging circuit will be turned on to discharge the electric charge on output capacitor, and decrease the voltage of V_{OUT} in very short time. The Auto-Discharging function is optional.

Output Voltage

The output voltage is adjustable using external 2-resistors. For better performance of the circuit, the R2 value need to be between 30kΩ and 100kΩ. The output voltage is calculated by:

$$V_{OUT} = (1+R1/R2)*0.75 (V)$$

Absolute Maximum Ratings

Stresses beyond those listed under “Absolute Maximum Ratings” may cause permanent damage to the device. These are stress ratings only and functional operation of the device at these or any other condition beyond those indicated in the operational sections of the specifications is not implied. Exposure to absolute maximum rating conditions for extended periods may affect device reliability.

Parameter	Rating	Unit
Input Voltage	-0.3 to 6	V
Input Voltage (CE Pin)	-0.3 to 6	V
Output Voltage	-0.3 to VIN+0.3	V
Maximum Load Current	1000	mA
Maximum Power Consumption	1200	mW
Operating Junction Temperature	-40 to 125	°C
Storage Temperature	-65 to 150	°C
Lead Temperature (Soldering, 5sec)	260	°C

Recommended Operating Conditions

Symbol	Item	Rating	Unit
V _{IN}	Input Voltage	1.8 to 5.5	V
I _{OUT}	Output Current	0 to 1000	mA
T _a	Operating Ambient Temperature	-40 to 85	°C
C _{IN}	Effective Input Ceramic Capacitor Value	1 to 10	μF
C _{OUT}	Effective Output Ceramic Capacitor Value	1 to 10	μF
ESR	Input and Output Capacitor Equivalent Series Resistance (ESR)	5 to 100	mΩ

Electrical Characteristics

(Unless otherwise noted, $V_{IN} = V_{SET} + 1.0V$, $T_a = -40^{\circ}C \sim 85^{\circ}C$, $C_{IN} = C_{OUT} = 1\mu F$ (effective capacitance⁽⁴⁾); Typical values are at $V_{IN} = V_{SET} + 1.0V, T_a = 25^{\circ}C$)

PARAMETER	SYMBOL	TEST CONDITIONS	MIN	TYP	MAX	UNIT
Input Voltage Operation Range	$V_{IN}^{(1)}$	$V_{IN} \geq V_{SET} + 0.5V$	1.8		5.5	V
Output Voltage	V_{OUT}	$I_{OUT} = 1mA, T_a = 25^{\circ}C$	$\times 0.98$		$\times 1.02$	V
		$I_{OUT} = 1mA \sim 1A, T_a = 25^{\circ}C$	-30		+30	mV
Dropout Voltage	$V_{DROP}^{(2)}$	$V_{OUT} = 3.3V, I_{OUT} = 1A,$ V_{OUT} drooping to $0.98 \times V_{OUT}$	60	100	140	mV
Supply Quiescent Current	I_{Q_ON}	Active mode: $V_{CE} = high.$ $I_{OUT} = 0mA$	70	110	150	μA
Supply Shutdown Current	I_{Q_OFF}	$V_{CE} = 0V$		1	3	μA
Output Voltage Line Regulation	Reg_{LINE}	$V_{SET} + 0.5V \leq V_{IN} \leq 5.5V$ ($V_{IN} \geq 1.8V$), $I_{OUT} = 10mA$ ($\Delta V_{OUT} / \Delta V_{IN} / V_{OUT}$)		0.02	0.1	%/V
Output Voltage Load Regulation	Reg_{LOAD}	I_{OUT} from 1mA to 1A $V_{IN} = V_{set} + 0.5V$ (ΔV_{OUT})		5	30	mV
Line Transient (The absolute value of the output change)	$V_{TRLN}^{(3)}$	$V_{OUT} = 3.3V, I_{OUT} = 1mA, V_{IN} = 4.3V$ to 5.5V in 10us, $T_a = 25^{\circ}C$		15	30	mv
		$V_{OUT} = 3.3V, I_{OUT} = 1mA, V_{IN} = 5.5V$ to 4.3V in 10us, $T_a = 25^{\circ}C$		15	30	
Load Transient (The absolute value of the output change)	$V_{TRLD}^{(3)}$	$V_{OUT} = 3.3V, V_{IN} = 4.3V, I_{OUT}$ from 1mA to 1000mA in 10us, $T_a = 25^{\circ}C$		75	120	mv
		$V_{OUT} = 3.3V, V_{IN} = 4.3V, I_{OUT}$ from 1000mA to 1mA in 10us, $T_a = 25^{\circ}C$		75	120	
Output Current	I_{OUT}		1000			mA
Over Current Limit	I_{LMT}	$V_{OUT} = 3.3V, V_{IN} = 4.3V,$ $T_a = 25^{\circ}C$	1050	1400	1900	mA
Short Current Limit	I_{SHORT}	$V_{OUT} = 0V, T_a = 25^{\circ}C$	60	130	200	mA
Inrush Current Limit	I_{RUSH}	$V_{OUT} = 3.3V, V_{IN} = 4.3V,$ $T_a = 25^{\circ}C$	400	600	800	mA
Power Supply Rejection Ratio	$PSRR^{(3)}$	$f = 1kHz, C_{OUT} = 1\mu F,$ $I_{OUT} = 20mA,$ $V_{IN} = 4.3V, T_a = 25^{\circ}C$		70		dB
Output Noise	$e_N^{(3)}$	10Hz to 100kHz, $I_{OUT} = 30mA,$ $C_{OUT} = 1\mu F,$ $T_a = 25^{\circ}C$		50* V_{OUT}	80* V_{OUT}	μV_{RMS}

EN Low Threshold	V_{IL}	$V_{IN}=1.8$ to $5.5V$			0.3	V
EN High Threshold	V_{IH}	$V_{IN}=1.8$ to $5.5V$	1			V
CE Pull-down Current	I_{CE}	$V_{IN}=4.3V$, $V_{CE}=4.3V$, $T_a=25^{\circ}C$		0.3	1	μA
Output resistance of auto discharge at off state	R_{LOW}	$V_{EN}=0V$, $V_{IN}=4V$, $I_{OUT}=10mA$	30	60	100	Ω
Thermal Shutdown Temperature	$T_{TSD}^{(3)}$	Junction Temperature Rising	135	155	175	$^{\circ}C$
Thermal Shutdown Released hysteresis	$T_{HYS}^{(3)}$	Junction Temperature falling from shutdown	20	40	60	$^{\circ}C$
ESD	HBM	Reference: ESDA/JEDEC JS-001-2017	± 4000			V
	CDM	Reference: ESDA/JEDEC JS-002-2014	± 1500			V

Note (1): Here V_{IN} means internal circuit can work normal. If $V_{IN} < V_{OUT}$, Reverse current protection circuit will work .

Note (2): V_{DROP} FT test method: test the V_{OUT} voltage at $V_{set} + V_{DROPMAX}$ with output current.

Note (3): Guaranteed by design and characterization. not a FT item.

Note (4): Effective capacitance, including the effect of DC bias, tolerance and temperature.

Application Circuits

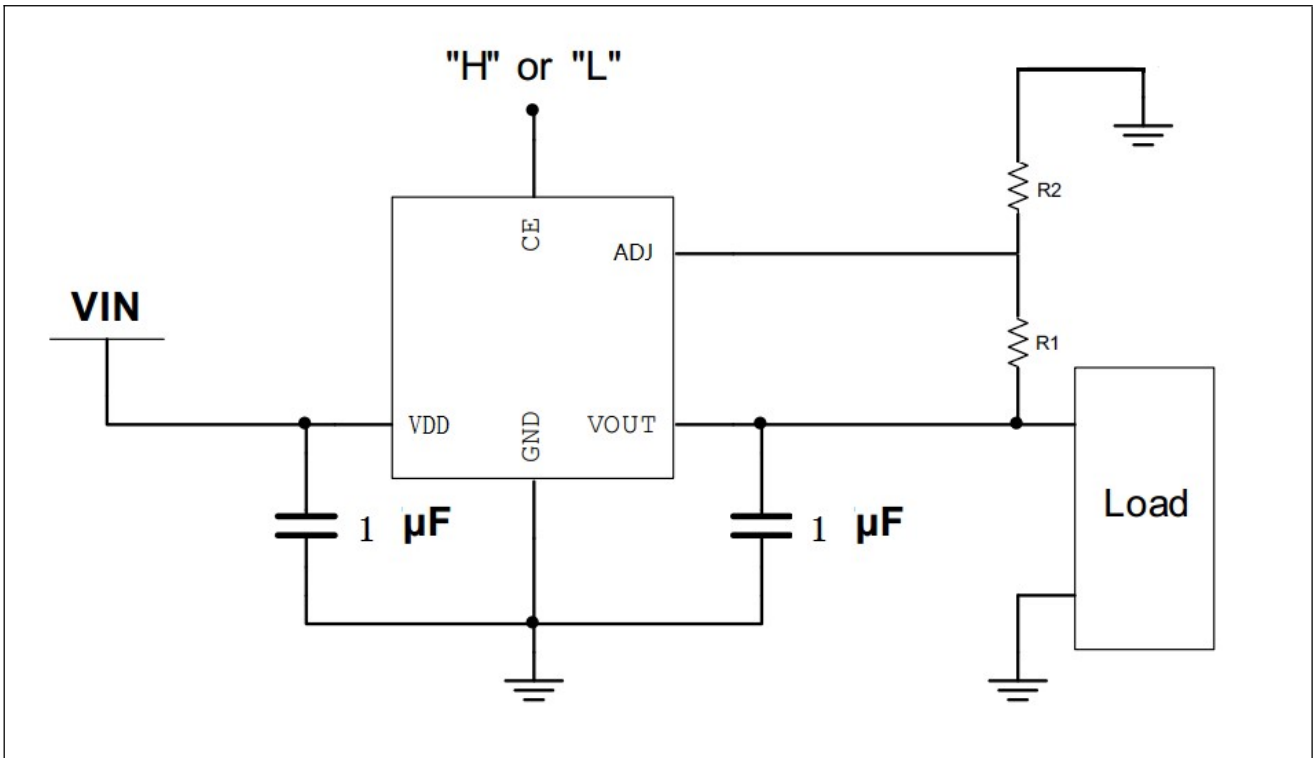

Package Dimension

